

**FEATURES**

- Standard 2.5mm x 2.0mm 4-Pad Surface Mount Package
- HCMOS Output
- Fundamental and 3<sup>rd</sup> Overtone Crystal Designs
- Frequency Range 1 – 110 MHz
- Frequency Stability  $\pm 50$  ppm Standard,  $\pm 25$  ppm and  $\pm 20$  ppm Available
- Operating Voltages +1.8Vdc, +2.5Vdc or +3.3Vdc
- Operating Temperature to -40°C to +85°C
- Output Enable Standard
- Tape & Reel Packaging Standard, EIA-418
- **RoHS/Green Compliant [6/6]**

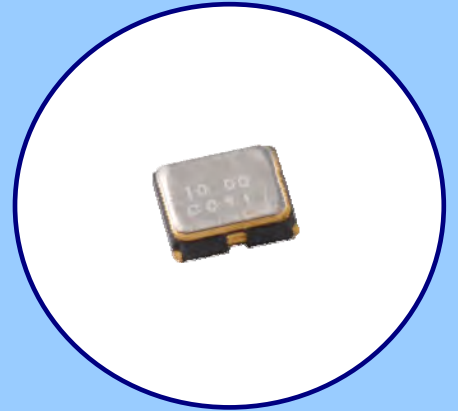

**APPLICATIONS**

Model 625 is ideal for applications; such as broadband access, Ethernet/Gigabit Ethernet, microprocessors/DSP/FPGA, networking equipment computers and peripherals, digital video, cameras and other portable devices.

**ORDERING INFORMATION**

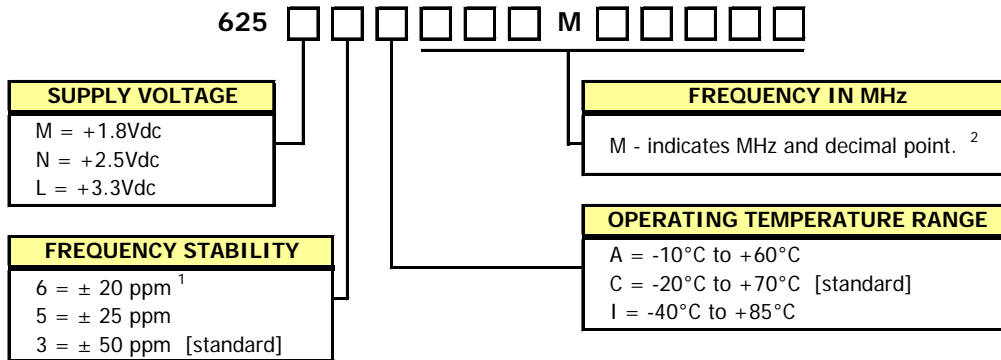

1] Consult factory for 6I Stability/Temperature availability.  
 2] Frequency is recorded with three leading significant digits before the 'M' and 5 significant digits after the 'M' (including zeros).  
 [Ex. 3.579545 MHz, code as 003M57954; 14.31818 MHz, code as 014M31818; 125 MHz, code as 125M00000]

**Not all performance combinations and frequencies may be available.  
 Contact your local CTS Representative or CTS Customer Service for availability.**

**PACKAGING INFORMATION [reference]**

Device quantity is 1k pcs. minimum and 3k pcs. maximum per 180mm reel. **8mm tape width.**

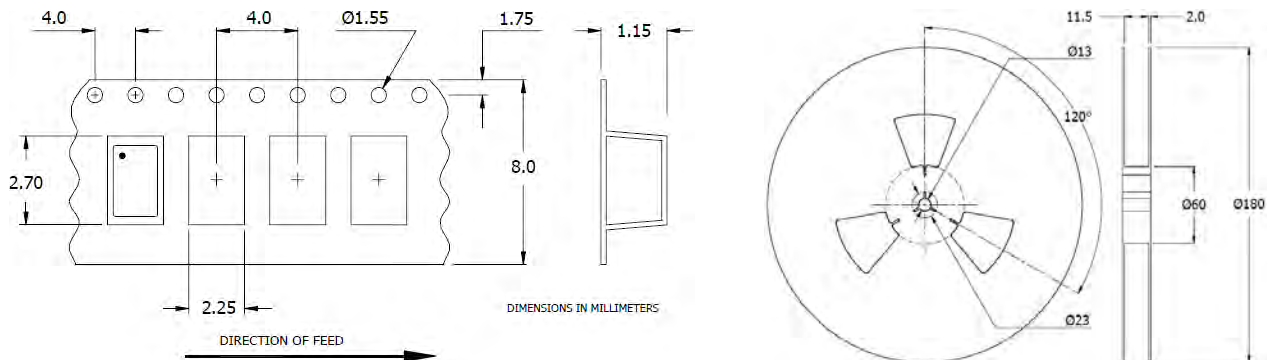

**MECHANICAL SPECIFICATIONS**

**PACKAGE DRAWING**

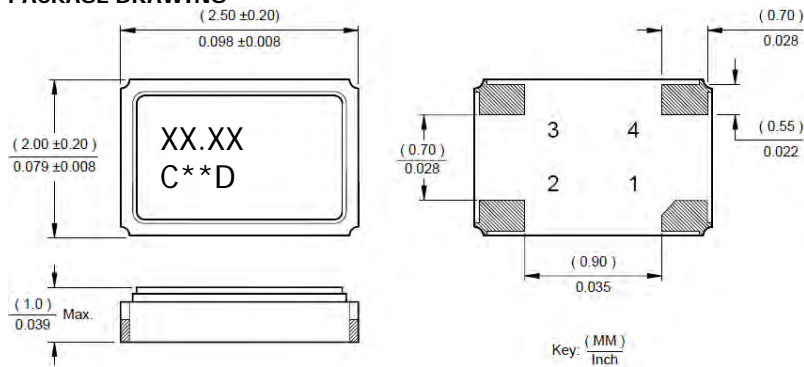

**MARKING INFORMATION**

1. XX.XX – Frequency in MHz.
2. C – CTS and Pin 1 identifier.
3. \*\* - Manufacturing Site Code.
4. D – Manufacturing Date Code.  
[See Table 1 for codes.]
5. Complete CTS part number, frequency value and date code information must appear on reel and carton labels.

**NOTES**

1. Termination pads [e4]. Barrier-plating is nickel [Ni] with gold [Au] flash plate.
2. Reflow conditions per JEDEC J-STD-020; 260°C maximum, 20 seconds.
3. MSL = 1.

**TABLE I**

YEAR					MONTH												
					JAN	FEB	MAR	APR	MAY	JUN	JUL	AUG	SEP	OCT	NOV	DEC	
2001	2005	2009	2013	2017	A	B	C	D	E	F	G	H	J	K	L	M	
2002	2006	2010	2014	2018	N	P	Q	R	S	T	U	V	W	X	Y	Z	
2003	2007	2011	2015	2019	a	b	c	d	e	f	g	h	j	k	l	m	
2004	2008	2012	2016	2020	n	p	q	r	s	t	u	v	w	x	y	z	

**SUGGESTED SOLDER PAD GEOMETRY**

C<sub>BYPASS</sub> should be ≥ 0.01 uF.

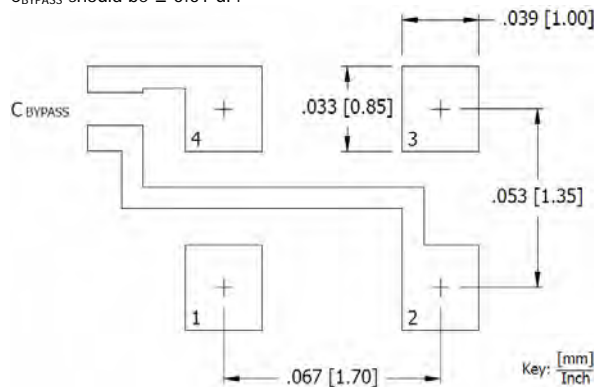

**D.U.T. PIN ASSIGNMENTS**

PIN	SYMBOL	DESCRIPTION
1	EOH	Enable
2	GND	Circuit & Package Ground
3	Output	RF Output
4	V <sub>CC</sub>	Supply Voltage