



actual size

# SMD Quartz Crystal · JXS42

4 Pad Version · 4.0 x 2.5 mm

- ± 10 ppm type available
- ceramic / metal package
- wave soldering temperature: 260 °C max.



## General Data

type	JXS42	
frequency range	12.0 ~ 12.99 MHz	(others on request)
frequency tolerance at 25 °C	± 10 ppm / ± 30 ppm	
load capacitance $C_L$	12 pF standard	(option: 8 pF ~ 30 pF / series)
shunt capacitance $C_0$	< 5 pF	
storage temperature	-40 °C ~ +90 °C	
drive level max.	100 µW	
aging	< ± 3 ppm first year	

## ESR (series resistance Rs)

frequency in MHz	vibration mode	ESR max. in Ω	ESR typ. in Ω
12.0 ~ 12.999	fund. - AT	100	45
13.0 ~ 18.999	fund. - AT	80	40
19.0 ~ 24.999	fund. - AT	60	25
25.0 ~ 29.999	fund. - AT	50	25
30.0 ~ 39.999	fund. - AT	50	20
40.00 ~ 50.00	fund. - AT	40	20

## Frequency Stability vs. Temperature

		± 10 ppm	± 15 ppm	± 20 ppm	± 30 ppm	± 50 ppm
-20 °C ~ +70 °C	STD.	○	○	○	●	○
-40 °C ~ +85 °C	T1		○	○	○	●

● standard  
 ○ available

## Marking

frequency with load capacitance code  
 company code / date code / internal code

date code: year/month  
 example: 6A = 2006 January

Jan.	Febr.	Mar.	Apr.	May	June
A	B	C	D	E	F

July	Aug.	Sept.	Oct.	Nov.	Dec.
G	H	J	K	L	M

## Dimensions

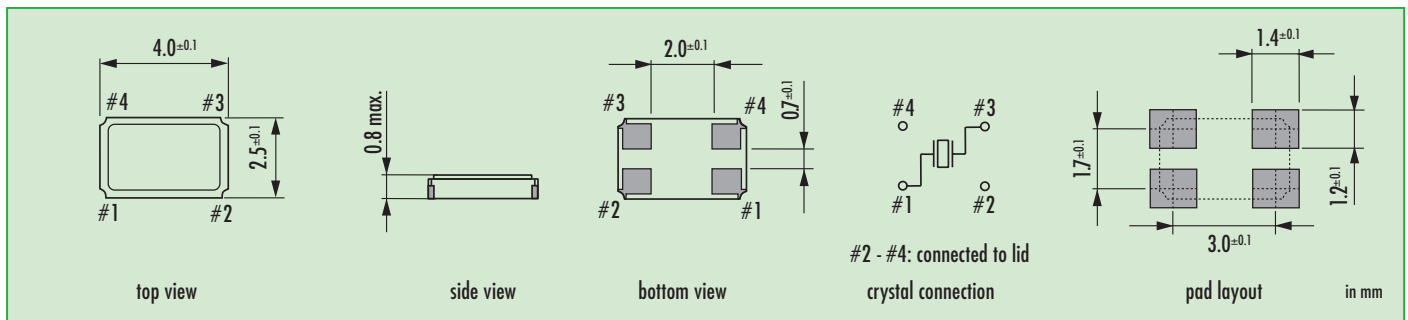

## Order Information

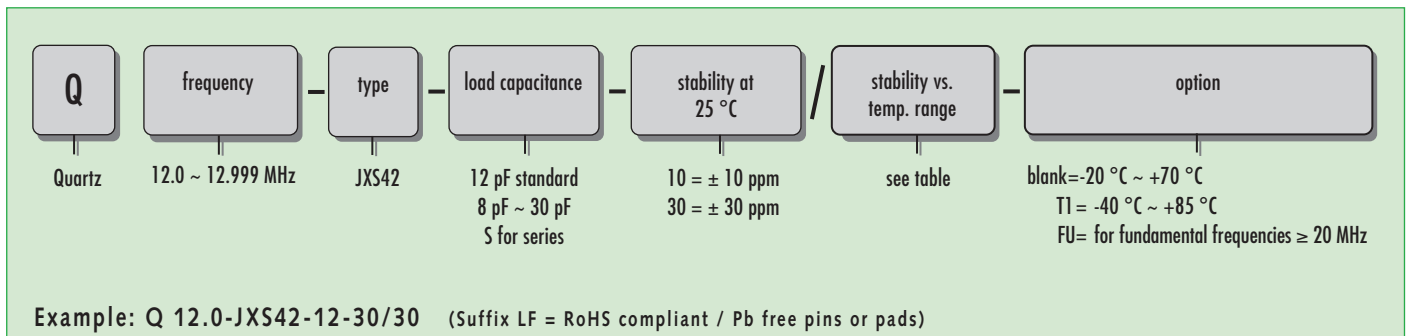

SHENZHEN YIJIN ELECTRONICS CO: LTD TEL: 0755-27876565

18924600166

QQ: 857950243

<http://www.vc-tcxo.com>